

- 30°C (50°C)
- 16
- DIN 2533
- DIN 19625
- DIN 2501
- DIN ISO 4064
- IP 68 (5)
- FLYPPER®
- IP 68 (5)



- EWG- A/B
- DN 65

- 350°

- FLYPPER®

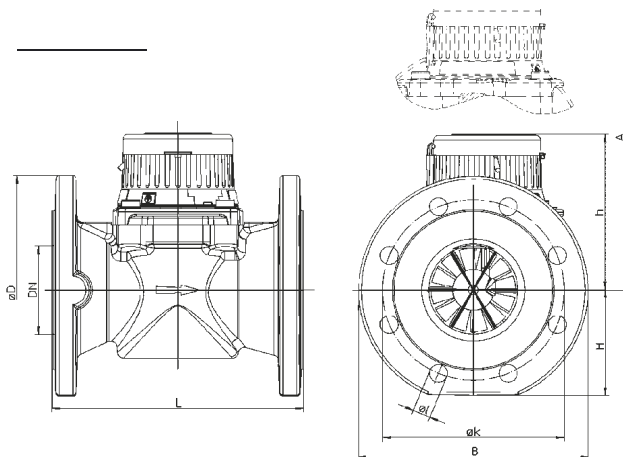
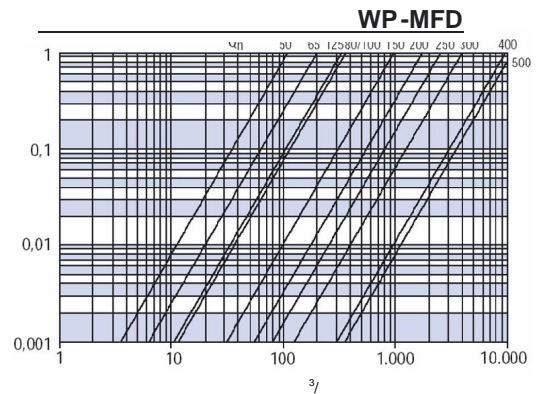

WP-MFD 80-125

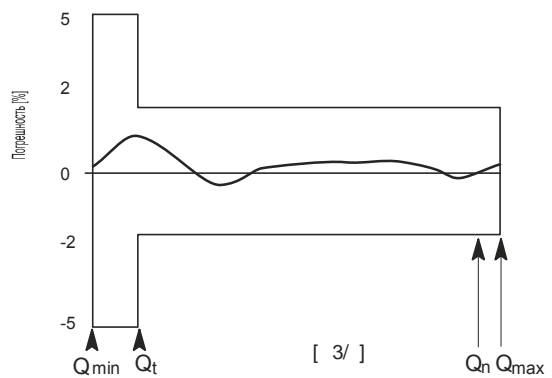

		222											
		WP-MFD											
		DN	50	65	80	100	125	150	200	250	300	400	500
DIN ISO 4064	Q _n M3/4		15	25	40	60	100	150	250	400	600	1000	1500
	Q _n M3/4		30	50	120	230	250	400	750	1.100	1.400	1.600	2.000
	Q _{max} M3/4		90	120	200	300	350	600	1.200	1.600	2.000	3.000	4.500
	M3/4		0,09	0,13	0,16	0,19	0,19	1,0	1,5	3	8	15	20
	Q _t M3/4		1	1,2	0,8	1,8	2	4	6	11	15	50	80
	Q _{min} M3/4		0,28	0,35	0,4	0,48	0,6	1,6	3,8	5,8	11,8	29,6	44,5
0,1	Q _t M3/4		1,8	2,0	0,8	1,8	2	4	6	-	-	-	-
	^{3/4}		-	-	-	-	-	-	-	-	-	-	-
	M3/4		0,4	0,5	0,5	0,6	0,6	1,8	4	-	-	-	-
	MM		200	200	225 (200)	250	250	300	350	450	500	500	500
	H MM		75	83	89	105	115	135/143	163/180	193	230	290	360
	h MM		123	123	154	154	154	245	245	242	290	311	361
	A		225	225	275	275	275	475	475	472	520	580	660
(PN16)	B		155	155	200	220	250	285	340	405	460	580	715
(PN16)	D		165	185	200	220	250	285	340	405	460	580	715
(PN16)	K		125	145	160	180	210	240	295	350/355	400/410	515/525	620/650
(PN16)	I		4	4	8/4	8	8	8	8/12	12	12	16	20
(PN16)	I		18	18	18	18	18	22	22	23/27	23/27	27/30	27/33
PN			16	16	10/16	16	16	16	10/16	10/16	10/16	10/16	10/16
[PN16]			10,2	11,2	13*16	21,5	39	47	75	165	190	300	
[PN40]			11,2	12,2	13*16,5	-	43	60	-	-	-	-	
BR570	/		100				1.000				10.000		
			1.000				10.000				100.000		
BR570	/		25 • 50 • 250 • 500				250 • 500 • 2.500 • 5.000				2.500 • 5.000		
											25.000 • 50.000		
(IR) BR 573	/		1				10				100		

В рамках технического развития возможны изменения данных.

222	50	WP-MFD		B-H	222 000 02
222	65	WP-MFD		B-H	222 000 04
222	80	WP-MFD	4	/ B	222 000 21
222	80	WP-MFD	8	/ B	222 000 00
222	100	WP-MFD		B	222 000 06
222	125	WP-MFD		B	222 000 07
222	150	WP-MFD		B	222 000 08
222	200	WP-MFD	8	, B	222 000 09
222	200	WP-MFD	12	, B	222 000 10
222	250	WP-MFD	PN 10	B	222 000 11
222	250	WP-MFD	PN 16	B	222 000 12
222	300	WP-MFD	PN 10	B	222 000 13
222	300	WP-MFD	PN 16	B	222 000 14
222	400	WP-MFD	PN 10	A	222 000 15
222	400	WP-MFD	PN 16	A	222 000 16
222	500	WP-MFD	PN 10	A	222 000 17
222	500	WP-MFD	PN 16	A	222 000 18

PN 25/40

P 68 (

ANSI BS
FLYPPER
5)